

REPLACEMENT PARTS

Supersedes: Nothing

e 530.18-RP2.3YI (796)

NOTE: FOR STYLE "A" MODELS SEE FORM 530.18-RP2.16YI.
FOR STYLE "C" & "D" MODELS SEE PAGES 8 THRU 11.

1 of 12

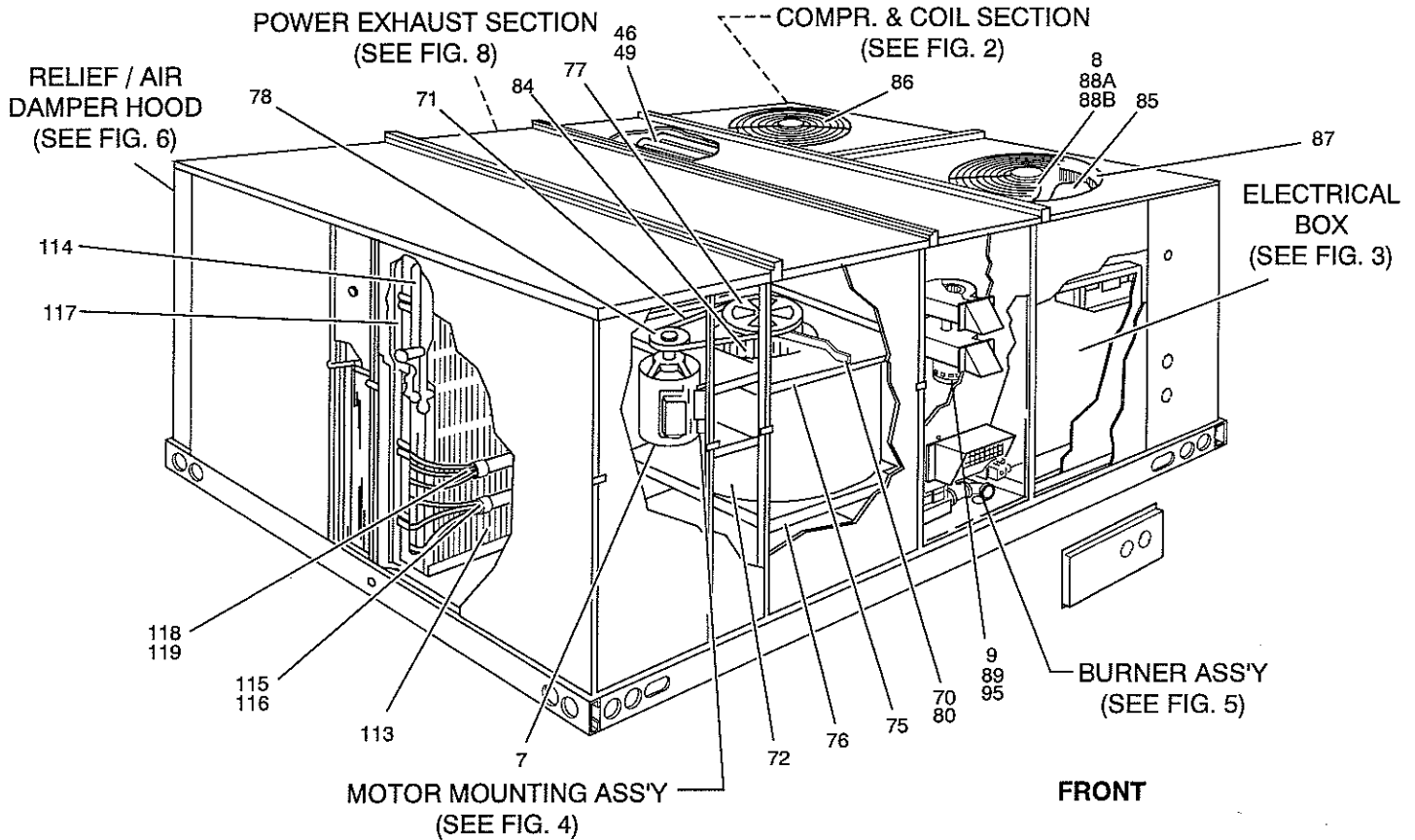

FIG. 1 – SINGLE PACKAGE GAS / ELECTRIC UNIT

COMPRESSOR

FIG	ITEM	DESCRIPTION	D2CG240N24050B (6-BURNER)
2	(1)	COMPRESSOR, DUAL HERMETIC (2-REQ'D)	015-02053-001
2	2	ISOLATOR, COMPRESSOR (12-REQ'D)	028-12342-700
2	3	SCREW, 5/16-18 HEX WASHER HD.W/SLEEVE	021-16047-700
	4	SPACE FOR FUTURE PART ADDITIONS	
	5	SPACE FOR FUTURE PART ADDITIONS	
	6	SPACE FOR FUTURE PART ADDITIONS	

MOTORS

1	(7)	MOTOR, BLOWER (7.5HP)	024-24123-003
1	(8)	MOTOR, FAN (2-REQ'D)	024-24121-701
1	(9)	MOTOR, VENTOR (1-REQ'D)	024-25005-702

ELECTRICAL

3	10	BOARD, CIRCUIT RELAY	031-00652-700
*	11	BOOT, RUBBER CAPACITOR	028-04133-000
3	12	CIRCUIT BREAKER [CB]	024-24055-000
*	13	CONNECTOR, CAP (6-CIRCUIT) (S9)	025-20963-000
*	14	CONNECTOR, PLUG (6-CIRCUIT) (P9)	025-19670-000

* NOT SHOWN

Major components and suggested stocking items are shown with item number in parenthesis "()".

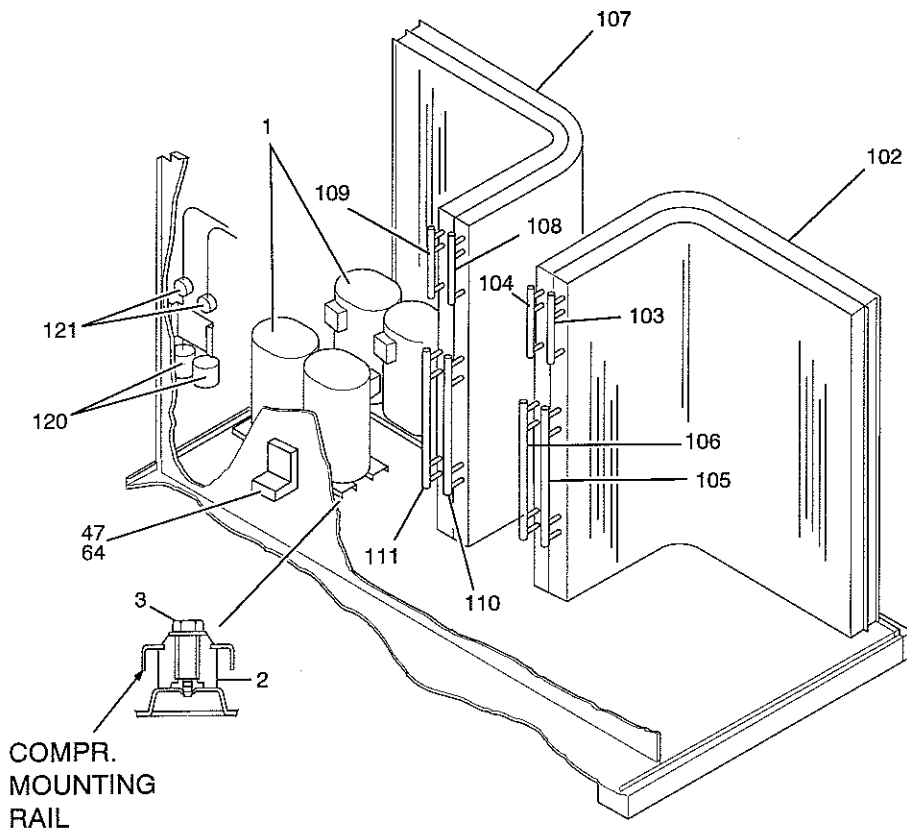

FIG. 2 - COMPRESSOR & COIL SECTION

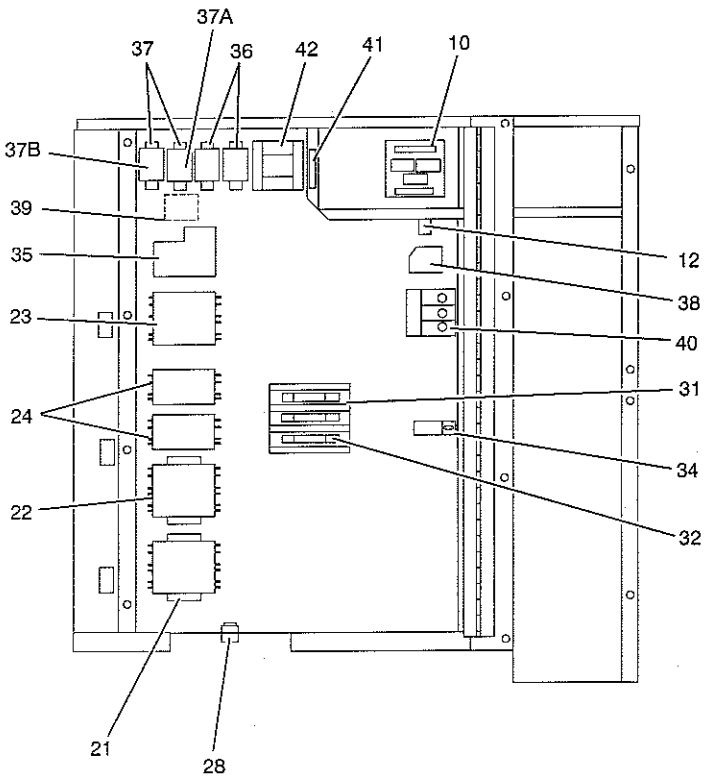
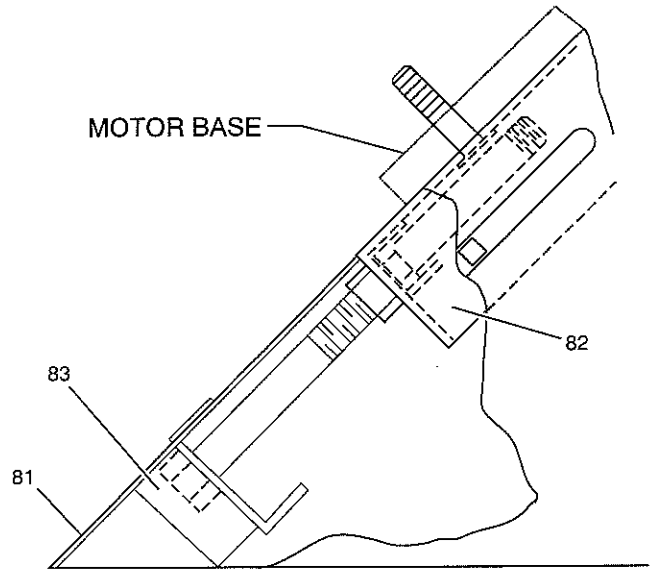

FIG. 3 - ELECTRICAL BOX



MOTOR MOUNTING / BELT TENSIONING ASSEMBLY
FIG. 4

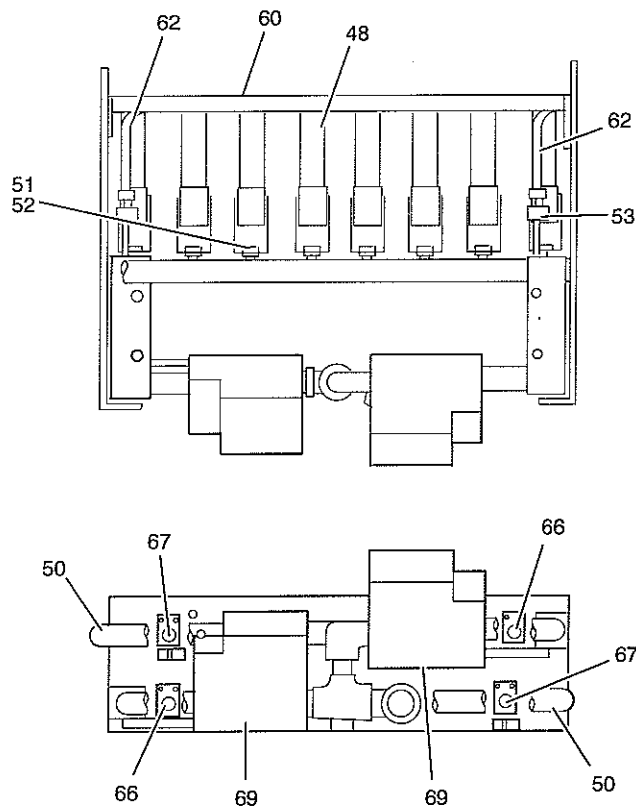

FIG. 5 - BURNER ASSEMBLY

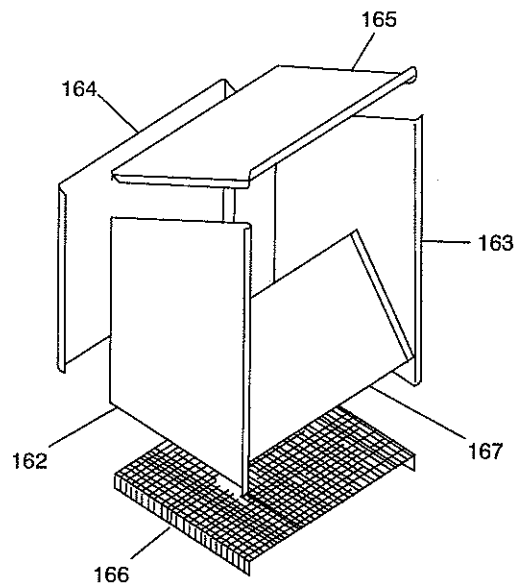

FIG. 6 - DAMPER HOOD (161)

ELECTRICAL (Cont.)

FIG	ITEM	DESCRIPTION	D2CG240N24050B (6-BURNER)
*	15	CONNECTOR, PLUG (9-CIRCUIT) (P7)	025-21192-000
	16	SPACE FOR FUTURE PART ADDITIONS	
	17	SPACE FOR FUTURE PART ADDITIONS	
	18	SPACE FOR FUTURE PART ADDITIONS	
*	19	CONTACT, SOCKET (BOX OF 50) (P7) (1)	025-19673-000
*	20	CONTACT, SPLIT PIN (BOX OF 50) (P6) (1)	025-20919-700
3	(21)	CONTACTOR, ELEC. [1M]	024-25842-700
3	(22)	CONTACTOR, ELEC. [2M]	024-25842-700
3	(23)	CONTACTOR, ELEC. [3M]	024-25842-700
3	(24)	CONTACTOR, ELEC. [4M,5M]	024-25838-700
*	(25)	CONTROL, PRESSURE (2-REQ'D) [HP1&2]	025-17620-014
*	(26)	CONTROL, PRESSURE (2-REQ'D) [LP1&2]	025-30249-700
*	(27)	CONTROL, LOW EVAP. TEMP. (2) [FS1&2]	025-27727-002
3	28	CONTROL, TEMP. [TLA]	025-27723-001
	29	SPACE FOR FUTURE PART ADDITIONS	
	30	SPACE FOR FUTURE PART ADDITIONS	
3	31	FUSEHOLDER, CRTG. 600V	025-18284-000
3	32	FUSE, DUAL 600V/15A (3-REQ'D) [7-9FU]	025-05741-000
3	32	FUSE, DUAL 600V/12A (3-REQ'D) [7-9FU]	---
*	33	LABEL, WIRING (REFERENCE)	035-12392-000
3	34	LUG, GROUND	025-19282-000
3	(35)	RELAY, BLOWER OVERLOAD [BOR]	024-24127-002
3	(36)	RELAY, CONTROL [RY1,2]	024-21678-000
3	(37)	RELAY, CONTROL [RW1,2]	024-19138-001

* NOT SHOWN

- (1) USE HAND TOOL #044-02999-700 WHEN APPLYING CONTACT.
- (2) USE HEAT CONDUCTIVE COMPOUND 013-02250-000 WHEN APPLYING CONTROL TO SUCTION LINE.

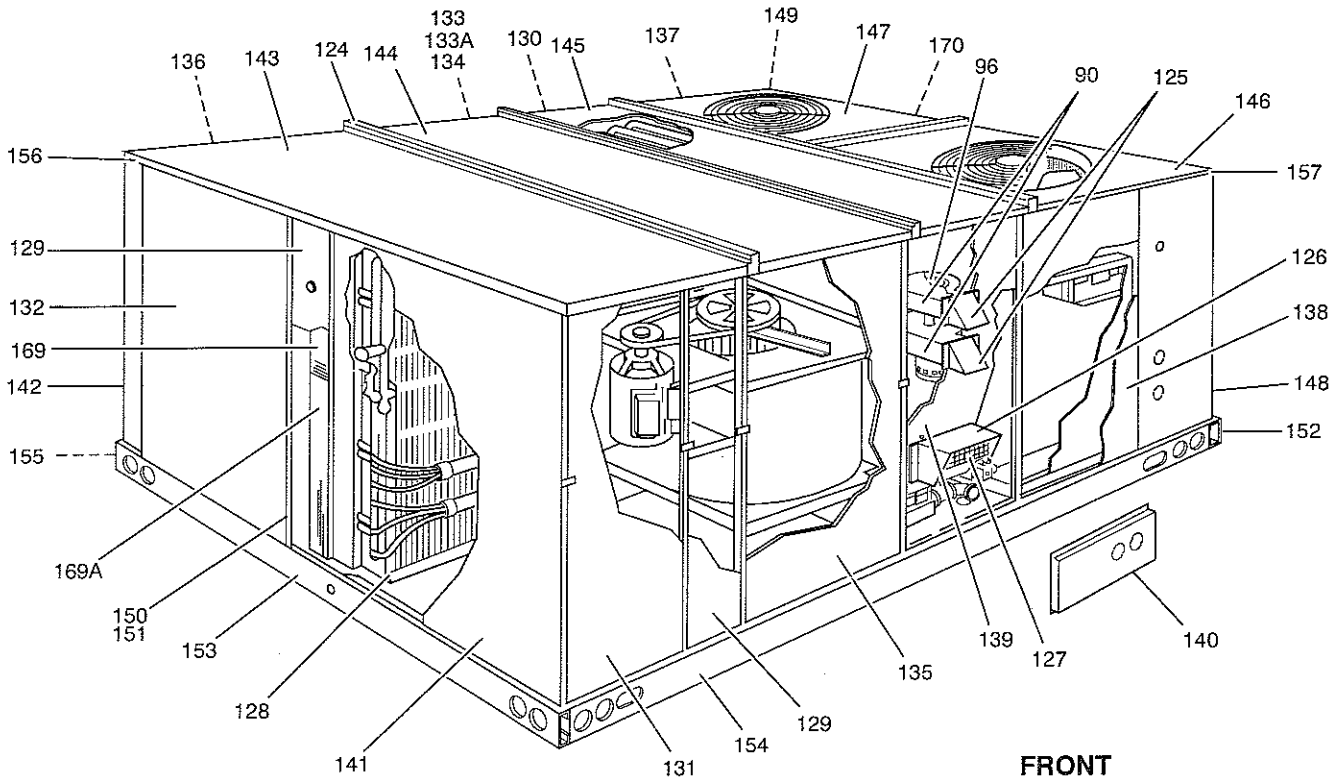

FIG. 7 - SINGLE PACKAGE GAS / ELECTRIC UNIT

ELECTRICAL (Cont.)

FIG	ITEM	DESCRIPTION	D2CG240N24050B (6-BURNER)
3	(38)	RELAY, HEAT SEQUENCE [TDR]	024-19082-038
3	39	RELAY, CONTROL (POWER EXHAUST) [EX2]	024-21292-700
3	40	TERMINAL BLOCK 3-POLE [2TB]	025-20710-000
3	41	TERMINAL BLOCK 3-POLE [4TB]	025-27755-000
3	(42)	TRANSFORMER [1T]	025-27732-000
	43	SPACE FOR FUTURE PART ADDITIONS	
	44	SPACE FOR FUTURE PART ADDITIONS	
	45	SPACE FOR FUTURE PART ADDITIONS	

GAS HEAT SECTION

1	46	BAFFLE, AIR (HEAT EXCH. TUBE) 1-PER TUBE	063-90071-000
2	47	BRACKET, LIMIT SWITCH	063-94987-700
5	48	BURNER, GAS (6-REQ'D)	029-20286-000
1	49	HEAT EXCHANGER	363-93846-001
5	50	MANIFOLD, GAS (2-REQ'D)	029-20081-000
5	51	ORIFICE, GAS BURNER #30 (6-REQ'D)	029-20423-030
5	52	ORIFICE, GAS BURNER BLANK (2-REQ'D)	029-20423-000
5	53	ORIFICE, GAS PILOT #65 (2-REQ'D)	029-20422-065
*	54	PANEL, FRONT FLUE BOX	063-93865-700
*	55	PANEL, TOP FLUE BOX	063-93867-700
*	56	PANEL, MIDDLE FLUE BOX	063-93866-700
*	57	PANEL, BOTTOM & SIDES FLUE BOX	063-93849-000
*	58	PANEL, VESTIBULE (FRONT)	363-94871-020
*	59	PANEL, VESTIBULE (BOTTOM)	363-94871-100
5	60	SUPPORT, BURNER	063-93848-000
	61	SPACE FOR FUTURE PART ADDITIONS	
5	62	TUBE, CARRYOVER (2-REQ'D)	029-20404-000

* NOT SHOWN

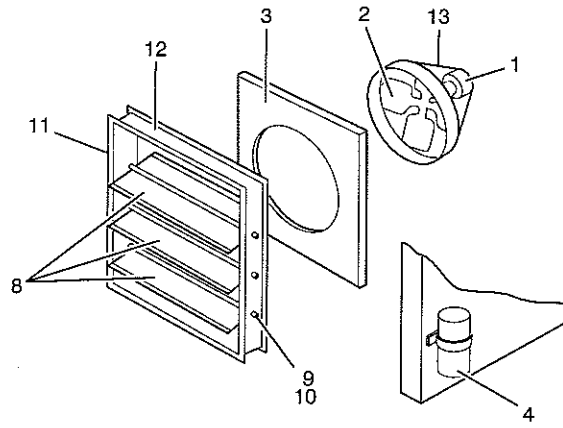

FIG. 8 – POWER EXHAUST SECTION - EXHAUST DAMPER ASS'Y (ITEM 7)

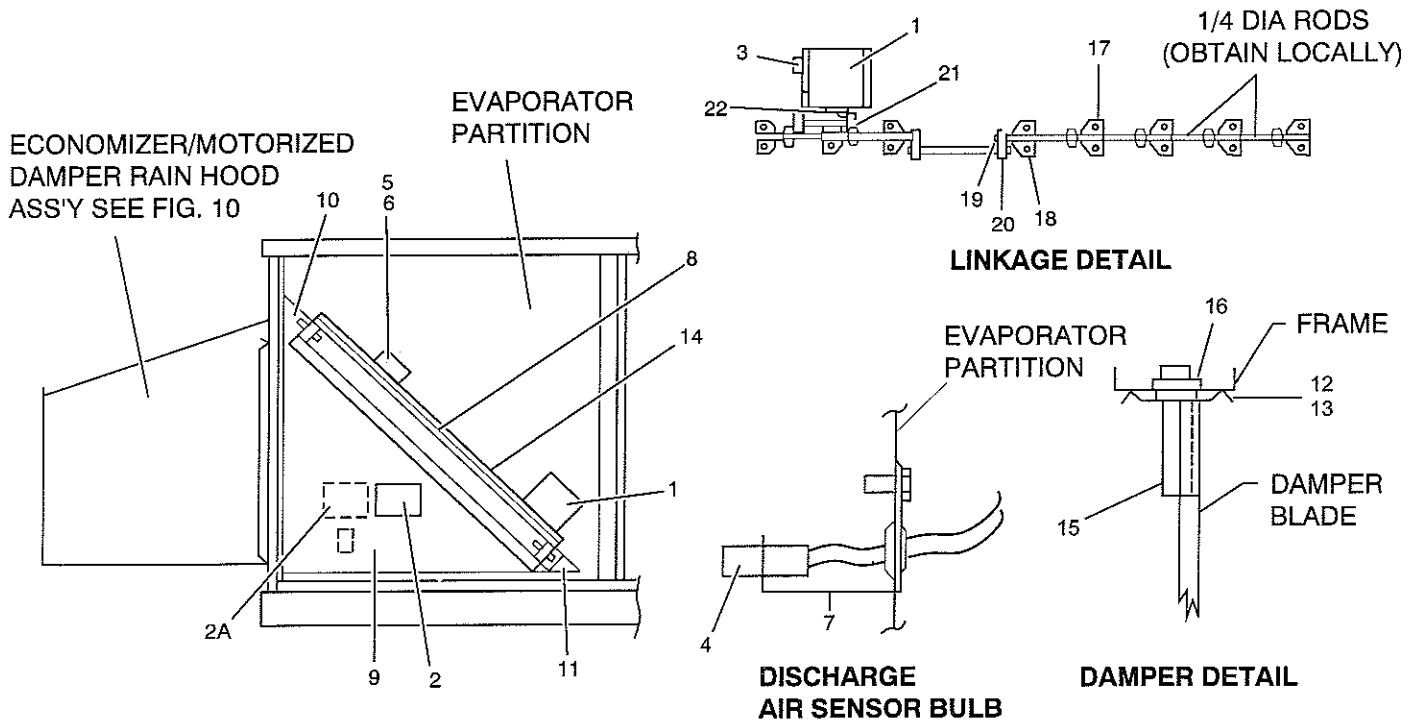

FIG. 9 – ELECTRONIC ENTHALPY ECONOMIZER / MOTORIZED DAMPER

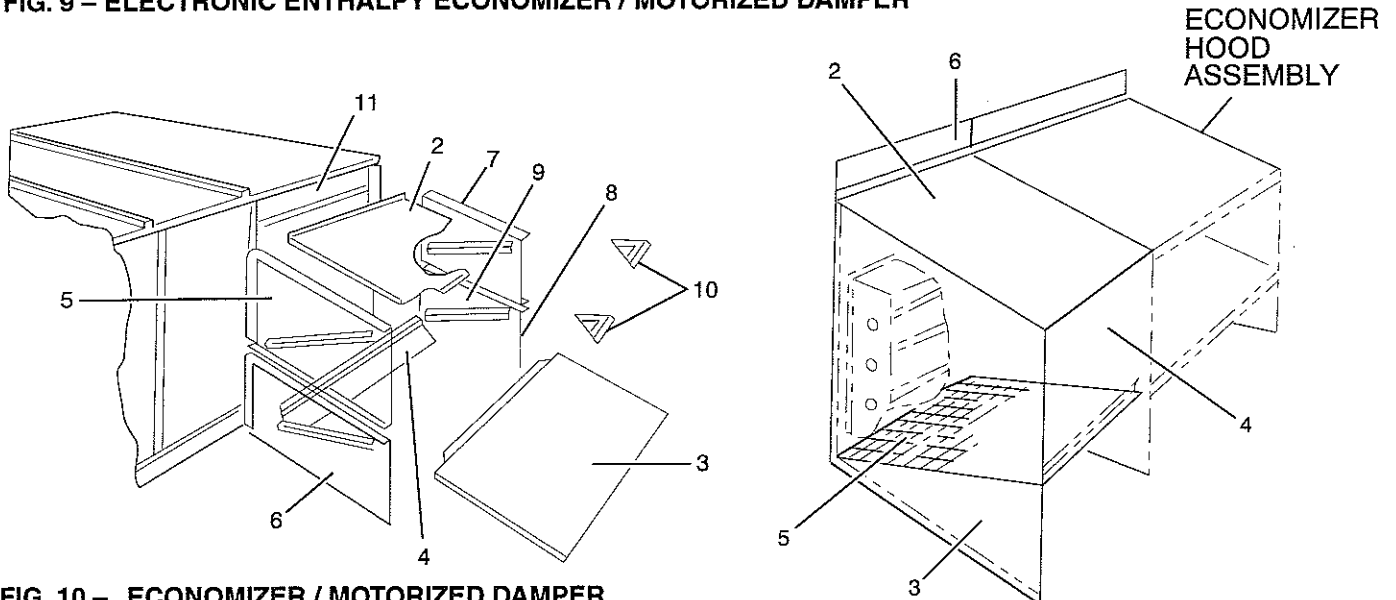

FIG. 10 – ECONOMIZER / MOTORIZED DAMPER RAIN HOOD ASSEMBLY (ITEM 1)

FIG. 11 – POWER EXHAUST RAIN HOOD ASSEMBLY (ITEM 1)

GAS/ELECTRIC CONTROLS

FIG	ITEM	DESCRIPTION	D2CG240N24050B (6-BURNER)
*	(63)	CONTROL, IGNITION [IC1&2]	025-27762-000
2	64	CONTROL, TEMP. (LIMIT) [LS]	025-26366-004
*	65	CONTROL, TEMP. (ROLLOUT)	025-27733-002
5	(66)	IGNITOR, SPARK (W/O TERM) (2-REQ'D)	025-27731-702
5	(67)	SENSOR, FLAME (W/TERM) (2-REQ'D)	025-27731-701
	68	SPACE FOR FUTURE PART ADDITIONS	
5	(69)	VALVE, GAS (HONEYWELL) (2-REQ'D)	025-27720-700

AIR MOVING (BLOWER)

1	70	BEARING, BALL 3-BOLT FLANGE (2-REQ'D)	029-20401-000
1	71	BELT, FAN (BX-81)	028-12017-000
1	72	HOUSING, BLOWER 18" W/O WHEEL	063-94675-000
*	73	KEY, STEEL 1/4 SQ. X 2" LG. (FIXED PULLEY)	001-07110-005
*	74	KEY, STEEL 1/4 SQ. X 6-3/8" LG. (WHEEL)	001-07110-004
1	75	PLATE, TOP 18" BLOWER	063-93868-000
1	76	PLATE, BTM. 18" BLOWER	063-93869-000
1	77	PULLEY, FIXED PITCH (BLOWER)	028-12012-000
1	78	PULLEY, VARIABLE PITCH (MOTOR)	028-12010-000
*	79	SHAFT, BLOWER	001-07116-000
1	80	SUPPORT, BEARING (WIREFORM) (2-REQ'D)	026-25552-000
4	81	SUPPORT, MOTOR MOUNTING	063-94674-000
4	82	PLATE, MOTOR MOUNTING W/4-WELD SCREWS	373-01957-000
4	83	BRACKET, TENSIONER (MOTOR SUPPORT)	063-94940-000
1	84	WHEEL, BLOWER 18"	026-25529-003

AIR MOVING (COND. FAN)

1	(85)	BLADE, FAN (2-REQ'D)	026-25553-000
1	86	GUARD, FAN (2-REQ'D)	026-25549-000
1	87	ORIFICE, FAN (2-REQ'D)	063-94820-000
1	88A	MOUNT, FAN MOTOR (WIREFORM) (2-REQ'D)	026-25551-000
1	88B	CLAMP RING FOR MOTOR MOUNT (2-REQ'D)	026-25568-000

AIR MOVING (VENTOR)

1	89	VARISTOR (VENTOR MOTOR PROTECTOR)	025-30145-000
7	90	HOUSING, VENTOR BLOWER (2-REQ'D)	063-90041-000
*	91	PLATE, VENTOR ORIFICE (TOP HSG.)	063-90038-020
*	92	PLATE, VENTOR ORIFICE (BOTTOM HSG.)	063-90038-021
*	93	PLATE, VENTOR (TOP HSG.)	073-03170-000
*	94	PLATE, VENTOR (BOTTOM HSG.)	073-03210-000
1	95	SPACER, VENTOR MOTOR (4-REQ'D)	073-03169-000
7	96	WHEEL, VENTOR BLOWER (UPPER)	026-25530-005
*	97	WHEEL, VENTOR BLOWER (LOWER)	026-25530-004
	98	SPACE FOR FUTURE PART ADDITIONS	

REFRIGERANT

*	99	CAP, SEAL 1/4 FLARE	023-11018-000
*	100	CORE, VALVE	022-02475-000
*	101	STEM, VALVE (1/4 OD TUBE)	022-08017-000
2	102	COIL, CONDENSER (FRONT FORMED) (3)	373-06295-700
2	102	COIL, COND. (FORMED/TECHNICOATED) (3)	373-06295-800
2	103	HEADER, COND. (FRONT COIL / TOP FRONT)	373-06295-730
2	104	HEADER, COND. (FRONT COIL / TOP REAR)	373-06295-740
2	105	HEADER, COND. (FRONT COIL / BTM. FRONT)	373-06295-730
2	106	HEADER, COND. (FRONT COIL / BTM. REAR)	373-06295-740
2	107	COIL, CONDENSER (REAR FORMED) (4)	373-06296-700

* NOT SHOWN

New replacement parts shown in **bold face** type at the first printing of Parts List code dated 7/96.

(3) INCLUDES HEADERS.

(4) INCLUDES HEADERS & TWO DISTRIBUTOR BODIES.

REFRIGERANT (Cont.)

FIG	ITEM	DESCRIPTION	D2CG240N24050B
			(6-BURNER)
2	107	COIL, COND. (FORMED/TECHNICOATED) (4)	373-06296-800
2	108	HEADER, COND. (REAR COIL / TOP FRONT)	373-06296-740
2	109	HEADER, COND. (REAR COIL / TOP REAR)	373-06296-730
2	110	HEADER, COND. (REAR COIL / BTM. FRONT)	373-06296-750
2	111	HEADER, COND. (REAR COIL /BTM. REAR)	373-06296-730
*	112	DISTRIBUTOR BODY (2-REQ'D)	026-23209-000
1	113	COIL, EVAPORATOR (SYS. 1 & 2) (5)	373-06228-700
1	114	HEADER, EVAP. (SYS. 1)	373-06228-720
1	115	VALVE, TXV (SYS. 1)	022-06852-001
1	116	VALVE, DISTR. ASS'Y. (INCL. 7 TUBES) (SYS. 1)	026-32679-703
1	117	HEADER, EVAP. (SYS. 2)	373-06228-730
1	118	VALVE, TXV (SYS. 2)	022-06852-001
1	119	VALVE, DISTR. ASS'Y. (INCL. 7 TUBES) (SYS. 2)	026-32679-703
2	120	FILTER, DRIER (2-REQ'D)	026-14777-712
2	121	INDICATOR, MOISTURE LIQUID (2-REQ'D)	026-12525-700
	122	SPACE FOR FUTURE PART ADDITIONS	
	123	SPACE FOR FUTURE PART ADDITIONS	

FABRICATED PARTS

7	124	CAP, ROOF (3-REQ'D)	063-94959-700
7	125	HOOD, FLUE OUTLET W/SCREEN (2-REQ'D)	363-93686-700
7	126	HOOD, AIR INLET W / O SCREEN	063-94817-000
7	127	SCREEN, AIR INLET	026-31407-000
7	128	PAN, DRAIN	373-03203-002
7	129	PANEL, ACCESS FILTER & MOTOR (2-REQ'D)	373-06317-180
7	130	PANEL, ACCESS HEAT SECT. (REAR)	373-06317-190
7	131	PANEL, ACCESS (LEFT FRONT)	373-06317-170
7	132	PANEL, ACCESS FRESH AIR (EVAP.END)	373-06317-210
7	133	PANEL, ACCESS (DAMPER MTG.) W/O ECONO.	363-94829-031
7	133A	COVER, DAMPER OPENING	363-94829-032
7	134	PANEL, ACCESS (ECONO. MTG.) W/ECONO.	373-06317-210
7	135	PANEL, ACCESS (BLOWER)	373-06317-210
7	136	PANEL, ACCESS (DAMPER)	373-06317-220
7	137	PANEL, ACCESS (COMPRESSOR)	063-93795-000
7	138	PANEL, ACCESS (CONTROLS)	063-93794-000
7	139	PANEL, ACCESS (HEAT SECT. FRONT, UPPER)	063-94770-000
7	140	PANEL, ACCESS (HEAT SECT. FRONT, LOWER)	063-94769-000
7	141	PANEL, CORNER (EVAP. SIDE FRONT)	373-06317-230
7	142	PANEL, CORNER (REAR L/H)	373-06317-200
7	143	PANEL, TOP (EVAP. L/H)	373-06208-140
7	144	PANEL, TOP (EVAP. R/H)	373-06317-150
7	145	PANEL, TOP (HEAT SECTION)	373-06317-160
7	146	PANEL, TOP (CONDENSER FRONT)	063-93750-000
7	147	PANEL, TOP (CONDENSER REAR)	063-93751-000
7	148	POST, CORNER (R/H FRONT)	063-93805-000
7	149	POST, CORNER (R/H REAR)	063-93786-000
7	150	POST, FRAME (INNER) (8-REQ'D)	073-10391-700
7	151	POST, FRAME (OUTER) (8-REQ'D)	063-94671-000
7	152	RAIL, BASE (COND. END)	073-10757-700
7	153	RAIL, BASE (EVAP. END)	073-10807-700
7	154	RAIL, BASE (FRONT)	073-01937-700
7	155	RAIL, BASE (REAR)	073-01938-700
7	156	RAIL, TOP (EVAP. END)	063-94943-700
7	157	RAIL, TOP (FRONT & REAR) (2-REQ'D)	063-94942-700
	158	SPACE FOR FUTURE PART ADDITIONS	
	159	SPACE FOR FUTURE PART ADDITIONS	
	160	SPACE FOR FUTURE PART ADDITIONS	

* NOT SHOWN

(4) INCLUDES HEADERS & TWO DISTRIBUTOR BODIES.
(5) INCLUDES HEADERS, TXV'S, DISTRIBUTOR VALVES & TUBES.

New replacement parts shown in **bold face** type at the first printing of Parts List code dated 7/96.

DAMPER HOOD

FIG	ITEM	DESCRIPTION	D2CG240N24050B (6-BURNER)
6	161	HOOD, DAMPER ASS'Y COMPLETE	373-02274-701
6	162	PANEL, DAMPER (RIGHT SIDE)	073-02266-700
6	163	PANEL, DAMPER (LEFT SIDE)	073-02267-700
6	164	PANEL, DAMPER (FRONT)	073-02268-700
6	165	PANEL, DAMPER (TOP)	073-02269-700
6	166	SCREEN, DAMPER (BLANK)	026-31409-700
6	167	BAFFLE, DAMPER	073-02272-700

MISC.

*	168	CATCH, MAGNETIC (2-REQ'D)	029-15650-000
7	169	FILTER, AIR (4-REQ'D)	(2x16x20)
7	169A	FILTER, AIR (4-REQ'D)	(2x16x25)
7	170	GUARD, COIL (2-REQ'D)	026-31432-702
*	171	GROMMET, PVC RED (2.375 HOLE)	028-04698-000
*	172	ELBOW, 90 DEG.	023-01643-000

* NOT SHOWN

POWER EXHAUST (OPTION) **STYLES "A", "B", "C", & "D"** (SEE BELOW)

POWER EXHAUST (OPTION)

FIG	ITEM	DESCRIPTION	D2CG240
8	1	MOTOR, 3/4 HP (460V)	024-24131-700
8	2	FAN, BLADE	026-25558-000
8	3	DECK, FAN	073-01888-000
8	4	CAPACITOR, RUN (12.5MFD)	024-21219-700
*	5	RELAY, CONTROL (1) [EX2]	SEE ITEM 39
*	6	BOOT, RUBBER CAPACITOR	028-04133-000
8	7	COMPLETE DAMPER ASSEMBLY	363-94996-005
8	8	BLADE, DAMPER (3-REQ'D)	073-01881-000
8	9	PIN, SLIDE (6-REQ'D)	029-18436-000
8	10	BUSHING, FLANGE (6-REQ'D)	029-18437-000
8	11	FRAME, DAMPER VERT. (2-REQ'D)	073-01932-000
8	12	FRAME, DAMPER HORIZ. (2-REQ'D)	073-01933-000
8	13	SUPPORT, FAN MOTOR	026-25563-000
*	14	CONNECTOR, CAP (2-CIRCUIT) PWR. EXHAUST	025-21159-000
*	15	CONNECTOR, CAP (3-CIRCUIT) PWR. EXHAUST	025-21193-000
*	16	CONNECTOR, PLUG (2-CIRCUIT) PWR. EXHAUST	025-19672-000
*	17	CONNECTOR, PLUG (3-CIRCUIT) PWR. EXHAUST	025-19671-000

(1) LOCATED IN MAIN CONTROL BOX.

ECONOMIZER, SINGLE & DUAL SENSOR UNITS (OPTION) **STYLES "A" & "B" ONLY** (SEE BELOW)
 ECONOMIZER, SINGLE SENSOR UNITS - **STYLES "C" & "D"** (SEE MODEL #2EE04701924)
 ECONOMIZER, DUAL SENSOR UNITS - **STYLES "C" & "D"** (SEE MODEL #2EE04701424)
 MOTORIZED AIR DAMPER (OPTION) **"STYLES "A" & "B"** (SEE BELOW)
 MOTORIZED AIR DAMPER **STYLES "C" & "D"** (SEE MODEL #2MD04702126)

**ECONOMIZER, SINGLE / DUAL SENSOR UNITS (OPTION)
 MOTORIZED AIR DAMPER (OPTION)**

FIG	ITEM	DESCRIPTION	D2CG240
9	1	MOTOR, ACTUATOR (ECONOMIZER - 25 & 46V)	025-26250-700
9	1	MOTOR, ACTUATOR (MTR. DAMPER - 25 & 46V)	025-26351-700
9	2	CONTROL, ENTHALPY (1), (3)	031-00863-000
9	2A	CONTROL, ENTHALPY (2), (3)	031-00863-000
9	3	CONTROL, LOGIC (3)	031-00862-700
9	4	SENSOR, TEMP (3)	031-00878-003
9	5	CONTROL, RELAY (3) [EX1]	024-19138-001
9	6	CONTROL, RELAY (3) [DR]	024-24111-000
9	7	BRACKET, SENSOR TEMP (3)	063-87678-000
9	8	BLADE, DAMPER (8-REQ'D)	063-94973-000
9	9	PARTITION, DIVIDER	073-13364-700
9	10	PLATE, PATCH (UPPER)	063-94974-700
9	11	PLATE, PATCH (LOWER)	063-94975-700
9	12	SEAL, DAMPER OUTSIDE AIR (16" LG.) (2-REQ'D)	029-20074-000
9	13	SEAL, DAMPER RETURN AIR (26" LG.) (2-REQ'D)	029-20097-700
9	14	SEAL, DAMPER BLADE (10-REQ'D)	029-20098-700
9	15	PIN, SLIDE (16-REQ'D)	029-18436-000
9	16	BUSHING, FLANGE (16-REQ'D)	029-18437-000
9	17	BRK'T, DAMPER BLADE (W/PIVOT) (5-REQ'D)	029-18448-000
9	18	BRK'T, DAMPER BLADE (W/2 PVTS) (3-REQ'D)	029-18449-000
9	19	CONNECTION, PIVOT	029-18438-000
9	20	PIVOT	029-18439-000
9	21	JOINT, BALL	029-08786-000
9	22	CRANK ARM, ACTUATOR	029-20090-000
*	23	PANEL, ACCESS (RETURN AIR)	SEE ITEM 134

- (1) USED ON BOTH SINGLE & DUAL SENSOR UNITS.
- (2) USED ON DUAL SENSOR UNITS ONLY.
- (3) NOT USED ON MOTORIZED AIR DAMPER OPTION.

ECONOMIZER / MOTORIZED DAMPER RAIN HOOD (ACCESSORY) **STYLES "A" & "B"** (SEE BELOW)
ECONOMIZER / MOTORIZED DAMPER RAIN HOOD (ACCESSORY) **STYLES "C" & "D"** (SEE MODEL #1EH0403)

ECONOMIZER RAIN HOOD

FIG	ITEM	DESCRIPTION	D2CG240
10	1	COMPLETE RAIN HOOD & HARDWARE W/FLTRS	363-94996-702
10	2	HOOD, RAIN (TOP)	073-01870-700
10	3	HOOD, RAIN (BTM W/FILTER RETAINER)	073-01871-700
10	4	HOOD, RAIN (FILTER RETAINER)	073-01872-700
10	5	HOOD, RAIN (UPPER L/H SIDE)	073-01873-700
10	6	HOOD, RAIN (LOWER L/H SIDE)	073-01875-700
10	7	HOOD, RAIN (UPPER R/H SIDE)	073-01874-700
10	8	HOOD, RAIN (LOWER R/H SIDE)	073-01876-700
10	9	ANGLE, SUPPORT FILTER (4-REQ'D)	073-01878-700
10	10	FILTER, AIR (2-REQ'D)	026-25557-700
10	11	PLATE, CLOSURE	073-01877-700

POWER EXHAUST RAIN HOOD **STYLES "A" & "B"** (SEE BELOW)
POWER EXHAUST RAIN HOOD **STYLES "C" & "D"** (SEE MODEL #1RD406)

POWER EXHAUST RAIN HOOD

FIG	ITEM	DESCRIPTION	D2CG240
11	1	COMPLETE POWER EXHAUST RAIN HOOD	363-94996-704
11	2	HOOD, RAIN (TOP)	073-01904-700
11	3	HOOD, RAIN (SIDE)	073-01905-000
11	4	HOOD, RAIN (FRONT)	073-01906-000
11	5	SCREEN	026-31408-000
11	6	PLATE, CLOSURE	073-01907-000

NOTE: **STYLE "B"** MODELS ARE THE SAME AS **STYLE "A"** EXCEPT FOR THE FOLLOWING PARTS:

FIG	ITEM	DESCRIPTION	D2CG240N24050B
*	(63)	CONTROL, IGNITION [IC1 & 2]	025-29012-000

NOTE: **STYLE "C"** MODELS ARE THE SAME AS **STYLE "B"** EXCEPT FOR THE FOLLOWING PARTS:

FIG	ITEM	DESCRIPTION	D2CG240N24050C
9	-	ECONOMIZER (SINGLE & DUAL)	SEE ECON. SECT.
10	-	ECONOMIZER (RAIN HOOD)	SEE ECON. SECT.
11	-	POWER EXHAUST (RAIN HOOD)	SEE P/E SECTION

NOTE: **STYLE "D"** MODELS ARE THE SAME AS **STYLE "C"** EXCEPT FOR THE FOLLOWING PARTS:

FIG	ITEM	DESCRIPTION	D2CG240N24050D
1	(9)	MOTOR, VENTOR	024-25005-004
*	33	LABEL, WIRING (REFERENCE)	035-13834-000
3	(38)	RELAY, HEAT SEQUENCE [TDR]	024-19082-740
2	64	CONTROL, TEMPERATURE (LIMIT) [LS]	025-26366-009
*	63	CONTROL, IGNITION [IC1 & 2]	025-29012-001
1	89	VARISTOR	OMIT
*	11	BOOT, RUBBER CAPACITOR	OMIT
7	126	HOOD, AIR INLET W/O SCREEN	073-16451-000
7	127	SCREEN, AIR INLET	026-34563-000
7	137	PANEL, ACCESS (COMPRESSOR)	063-93795-001
7	138	PANEL, ACCESS (CONTROLS)	063-93794-001
7	139	PANEL, ACCESS (HEAT SECT. FRONT, UPPER)	073-16452-004

* NOT SHOWN

New replacement parts shown in **bold face** type at the first printing of Parts List code dated 7/96.

FOR FACTORY OR FIELD INSTALLED ACCESSORIES SEE THE FOLLOWING PARTS LIST:

ACCESSORIES - ELECTRICAL

DESCRIPTION	MODEL NO.
ANTI-RECYCLE TIMER	2AC04700424
LOW AMBIENT TO 0 DEG. F (460V & 50HZ.)	2LA04703546
ECONOMIZER, (SINGLE ENTHALPY)	SEE ECONO. SECT
ECONOMIZER, (DUAL ENTHALPY)	SEE ECONO. SECT
MOTORIZED DAMPER	SEE ECONO. SECT

ACCESSORIES - NON-ELECTRICAL

DESCRIPTION	MODEL NO.
PROPANE CONVERSION KIT	1NP0418
HIGH ALTITUDE - NATURAL GAS	1HA0409
HIGH ALTITUDE - PROPANE	1HA0408
HIGH SPEED DRIVE	1LD0417



Heating and Air Conditioning



Proud Sponsor
of the 1996
U.S. Olympic Team
26USC80